

CREEKSIDE INDUSTRIAL PARK

Harrisburg, SD

(north of Cliff Ave & Willow St)



#BUILDINGMADEEASY

Executive Shops with Offices (Heated)

- Plan A - 40' x 60'
- Plan B - 34' x 60'
- Plan C - 28' x 60'
- Plan D - 28' x 60'

Contractor Shops / Heated Storage

- Plan A - 24' x 45'

Cold Storage

- Plan A - 15' x 45'
- Plan B - 15' x 25'



**For pricing and more
information, give us a call!**

605-275-5888
signaturecompaniesllc.com

All information deemed reliable but not guaranteed.

Executive Shops w/ Offices

#BUILDINGMADEEASY

- Office space (heated and cooled)
- Shop space (heated)
- Bathroom (1)
- Overhead door w/ remote
- Front + Rear parking
- Store front presence
- Drivethrough bay
- Security fencing & gated
- Floor Drain
- Natural Light

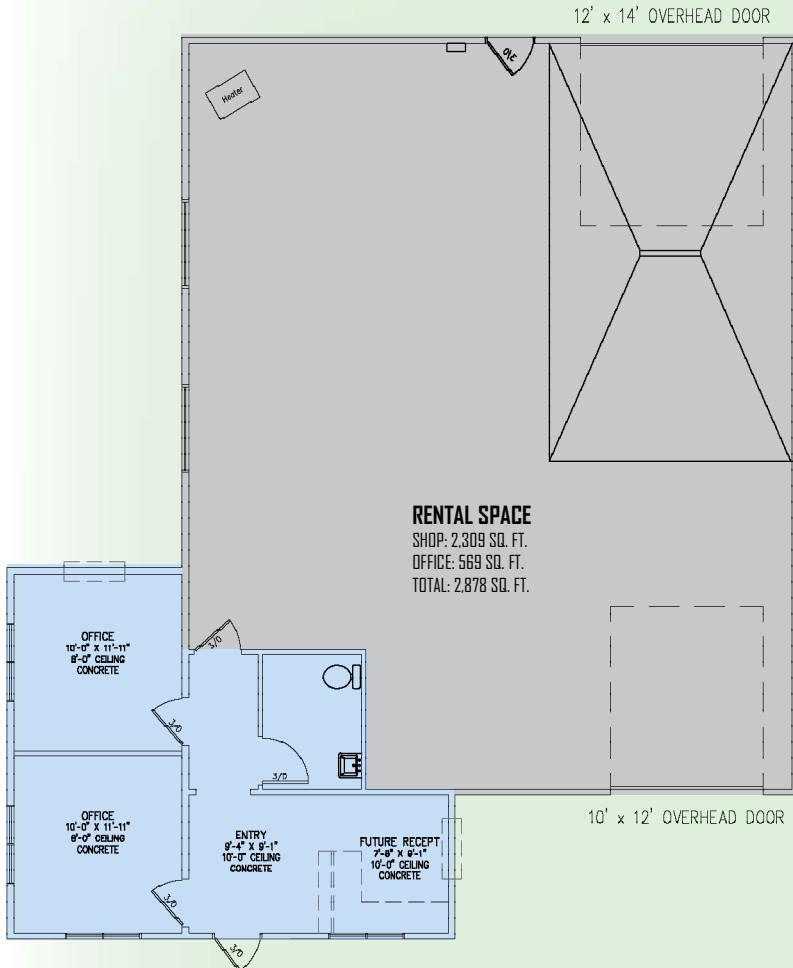

EXECUTIVE PLAN A

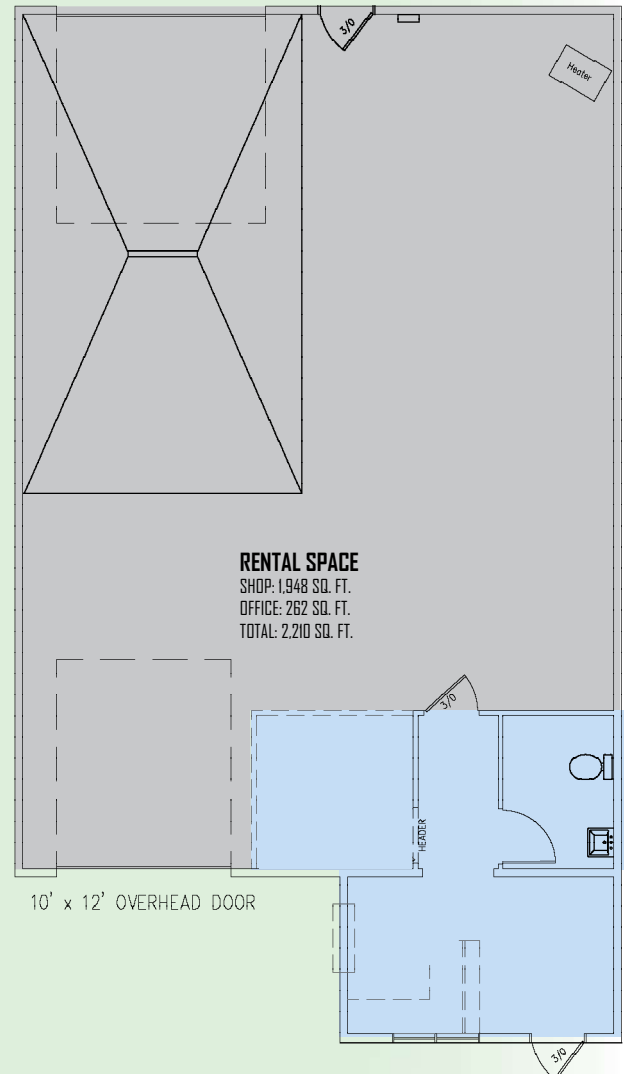

EXECUTIVE PLAN B

Tenant responsibilities

- Phone/cable/internet
- Electric
- Gas
- Garbage

Landlord responsibilities

- Water/sewer
- Snow
- Lawn
- Insurance

All information deemed reliable but not guaranteed.

605-275-5888
signaturecompaniesllc.com



Executive Shops w/ Offices

#BUILDINGMADEEASY

12' x 14' OVERHEAD DOOR

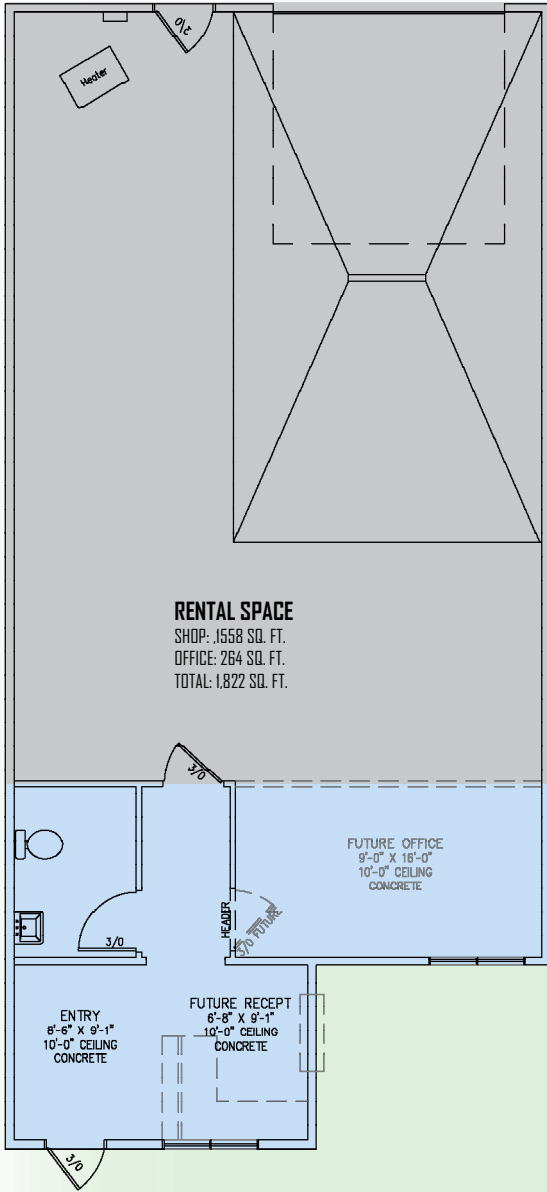

EXECUTIVE PLAN C

- Office space (heated and cooled)
- Shop space (heated)
- Bathroom (1)
- Overhead door w/ remote
- Front + Rear parking
- Store front presence
- Security fencing & gated
- Floor Drain
- Natural Light

12' x 14' OVERHEAD DOOR

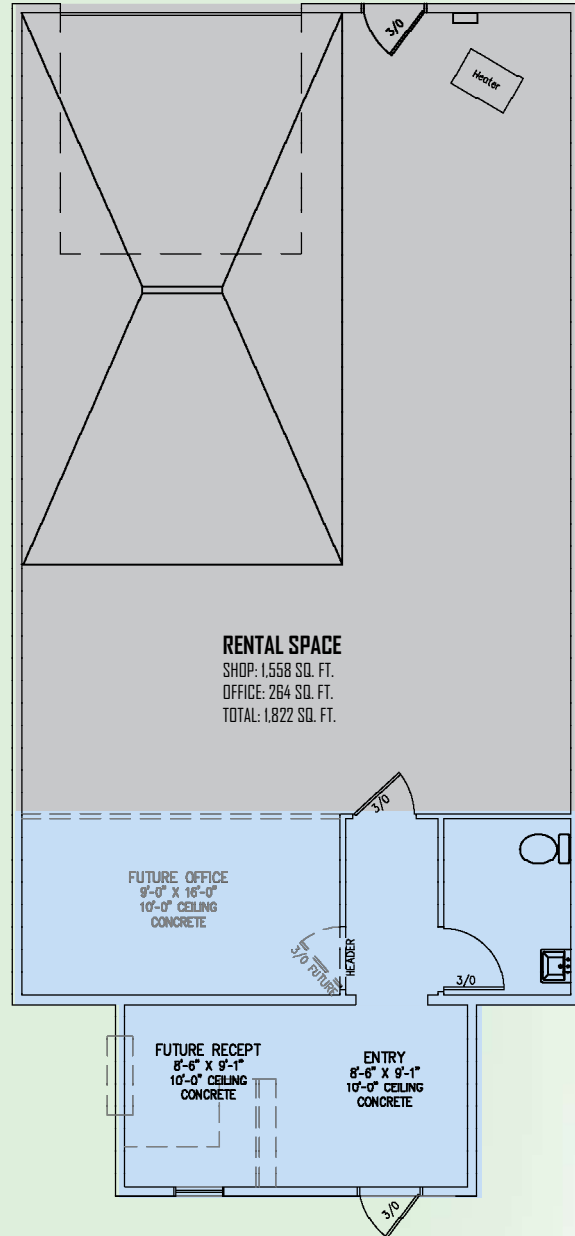

EXECUTIVE PLAN D

Tenant responsibilities

- Phone/cable/internet
- Electric
- Gas
- Garbage

Landlord responsibilities

- Water/sewer
- Snow
- Lawn
- Insurance

All information deemed reliable but not guaranteed.

605-275-5888
signaturecompaniesllc.com



FUTURE EXECUTIVE SHOPS

Executive Shops with Offices

- EXECUTIVE PLAN A
- EXECUTIVE PLAN B
- EXECUTIVE PLAN C
- EXECUTIVE PLAN D

| | |
|-----|---|
| 464 | X |
| 462 | X |
| 460 | X |
| 458 | |
| 456 | X |
| 454 | X |
| 452 | X |

| |
|---|
| X |
| X |
| X |
| X |
| X |
| X |
| X |

CLIFF AVE

X = Occupied

605-275-5888
signaturecompaniesllc.com



Contractor Shops & Cold Storage

#BUILDINGMADEEASY

CONTRACTOR PLAN A

- Heated storage & shop space
- Bathroom (1)
- Overhead door w/ remote
- Floor Drain

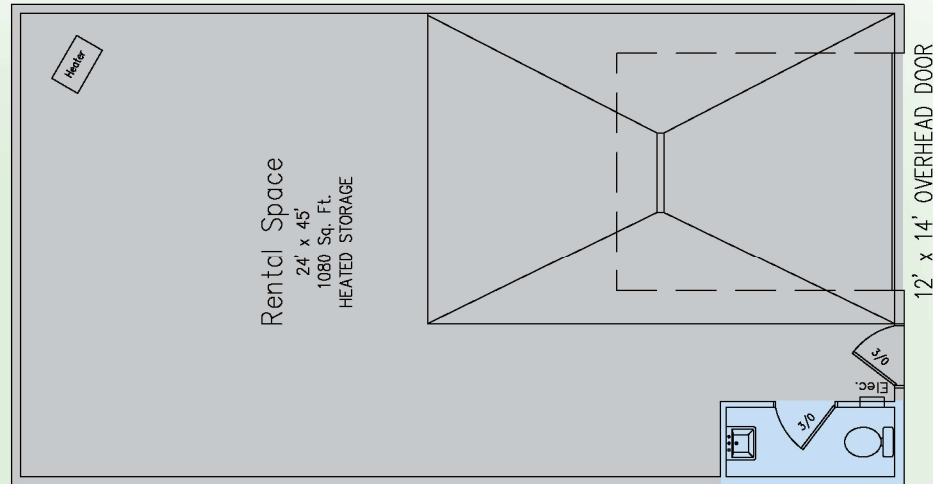

COLD STORAGE PLAN A

- Power and Light
- Overhead door w/ remote
- Unheated

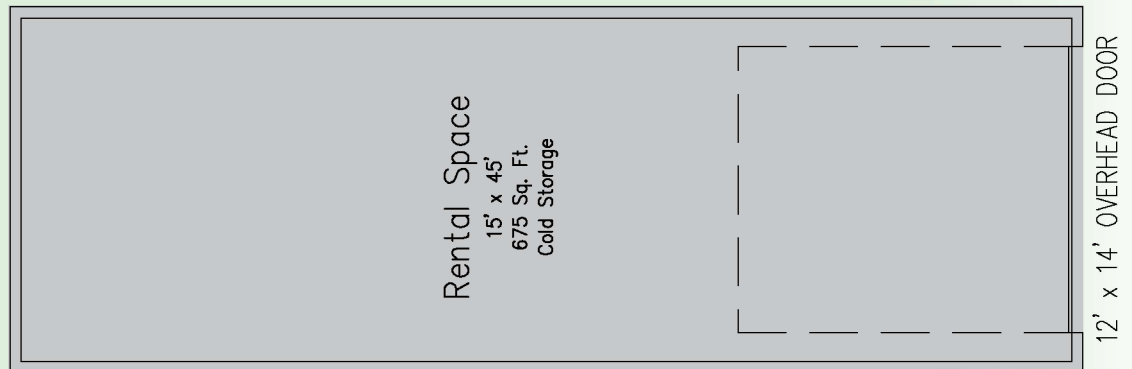

COLD STORAGE PLAN B

- Power and Light
- Overhead door (12' x 12') w/ remote
- Unheated

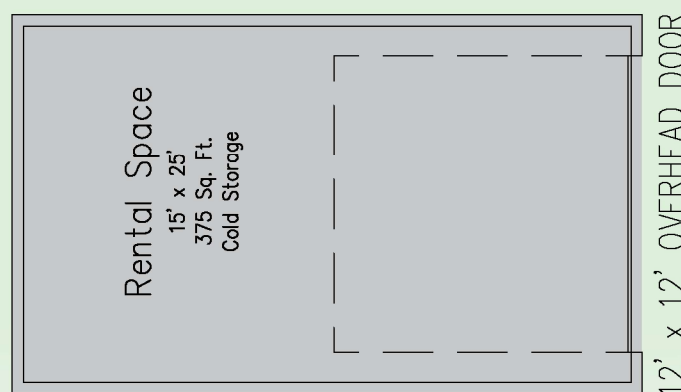

Tenant responsibilities

- Phone/cable/internet
- Electric
- Gas
- Garbage

Landlord responsibilities

- Water/sewer
- Snow
- Lawn
- Insurance

All information deemed reliable but not guaranteed.

605-275-5888
signaturecompaniesllc.com



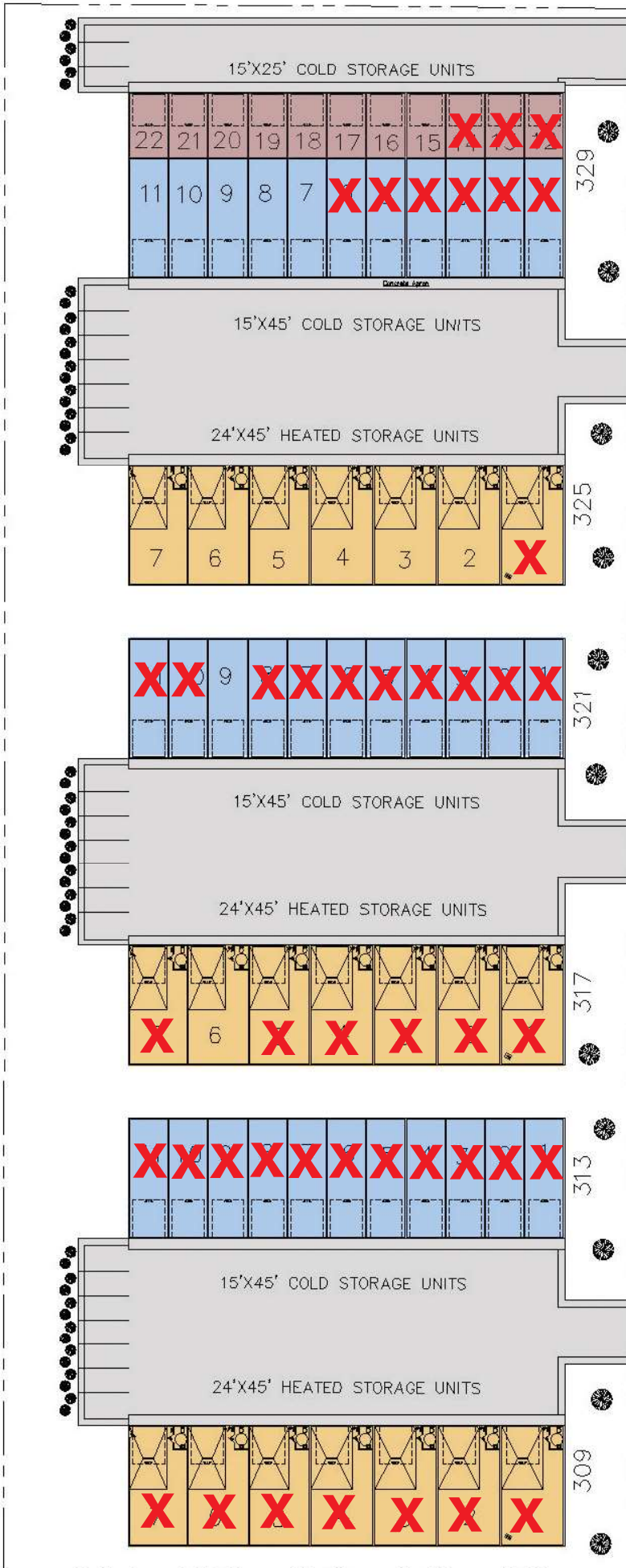

Contractor Shops & Cold Storage

- COLD STORAGE (15' X 25')
- COLD STORAGE (15' X 45')
- HEATED STORAGE (24' X 45')

X = Occupied

605-275-5888
signaturecompaniesllc.com

